

P11 | PATH LIGHT



PATHWAY/AREA LIGHTS | 25.5-37.5"H
3 - 15W (323-1710lm) | 10.5-16 VAC | Integrated LED

FEATURES

- Built for commercial-grade landscape lighting applications
- U.S.-made light engine and driver
- CNC-machined, corrosion-resistant 6061 aluminum.
- 180-degree vertical adjustable knuckle.
- Dimmable configurations available; see Specifications and ordering guide for details. Standard fixtures are non-dimmable.
- Built-in surge protector safeguards internal electronics from voltage fluctuations and power surges.
- High-strength tempered glass lens.
- High-performance 3-step bin LED with an L70 rating of over 100,000 hours.
- [20-year manufacturer limited warranty.](#)
- ETL listed to the UL 1838 standard, with IES Files Available (See page 4).
- **The P11 is a built-to-order-non-stock fixture with a 5-7 business day lead time.**



AVAILABLE FINISHES:

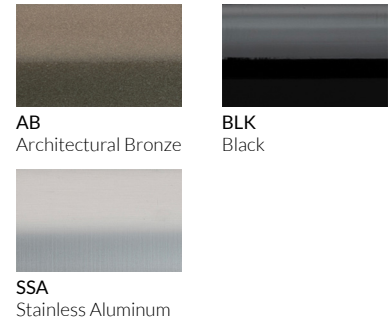

POWER CONSUMPTION

Candela Power & IES charts can be found on page 4

COLOR TEMPERATURE	WATTAGE	VA	LUMENS	ADDITIONAL COLOR TEMP OPTIONS	
● 3000K	3W	6VA	323LM	● 2700K	● 5000K
	9W	10VA	771LM	● Amber	● Blue
	12W	15VA	1408LM	● Royal Blue	● Green
	15W	18VA	1710LM	● Red	

*** Amber and red not available in 9W, 12W, or 15W.*

Materials

CNC-machined from billet 6061-T6 aluminum with 316 stainless steel hardware.

Finish

BLK/AB: Corrosion-resistant E-coat primer under a hard enamel finish that delivers strong UV protection.
SSA: Marine-grade anodization for lasting corrosion resistance and durability.

Extension Post Options

Offered in 24" or 36" extension post configurations. Each extension post is CNC-machined from billet 6061-T6 aluminum for strength, durability, and integrated appearance. (See page 2-3 for details).

Wattage

3, 9, 12, or 15W CREE LED delivering up to 1710lm (SSA finish).

Voltage

10.5-16VAC. Requires low voltage transformer or step down transformer.

Light Engine

US Built Led module with Cree Diode and Metal core PCB for better heat dissipation.
CRI 80 (CRI 90 upon request) CCT 2700K & 3000K. McAdam 3 step LED binning to ensure color consistency.

Optics

120° wide-angle flood.

Lead Wire

36" 18 AWG tinned copper.

Dimming Options

Standard fixtures are non dimmable. Dimmable Option valuable with constant current LED power supply connected in series with the fixtures. Dimming Method: Phase Dimming (TRI-AC/ELV) or 0-10V dimming.

Mounting

Mounting accessories not included; specify on ordering guide. Choose P11 Surface Mount for hard, flat surfaces or LV150 Heavy Duty Stake (4" D x 19" H). (See page 2-3 for details).

Listings

ETL listed to UL1838, IP66 Standard.



P11 | Path Light

PATHWAY/AREA LIGHTS

ORDERING GUIDE

EXAMPLE: P11-HIGH15-AB-2700K-36-P11 SURFACE MOUNT KIT BLK

MODEL

P11 P11 Path Light Light Fully Integrated	WATTAGE	OPTICS	FINISH	COLOR TEMPERATURE
	DIM (Dimmable)	F (Flood (Default/Blank))	AB (Architectural Bronze)	3000K (Default/Blank)
	LOW (3W)		BLK (Black)	2700K
	MID (9W)		SSA (Stainless Aluminum)	5000K
	HIGH12 (12W)			AMB (Amber)
	HIGH15 (15W)			BLU (Blue)
				RBL (Royal Blue)
				GRN (Green)
				RED (Red)

OPTIONAL ACCESSORIES

EXTENSIONS	Mounting
24 (24" Extension)	GROUND MOUNT
36 (36" Extension)	LV150 (LV150 Heavy Duty Stake 4"D X 19"H)
	SURFACE MOUNT
	P11 SURFACE MOUNT KIT XXX (P11 Mounting Base 3.965Ø" X 0.25" Thickness)

TRANSFORMERS

BUILD THE SKU LEFT → RIGHT

Pattern: [WATTAGE (VA)]-[MODEL]-[CONNECTION TYPE]

Items tagged "(Default/Blank)" are not included in the SKU.

EXAMPLE: 602-WLED SS-DW

WATTAGE (VA)	MODEL	CONNECTION TYPE
62 102 152 302 602 902 1202	WLED SS (Low Voltage Magnetic Transformer 15V Tap W/ LED & Surge Protection)	Pluggable 120VAC Plug-In (Default/Blank) DW (Direct Wire 120VAC)
60WNL	INLINE (60W No-Load Inline Electronic Transformer 120VAC Input, 12VAC Output)	Direct Wire 120VAC (Default/Blank)
60	MD (Mammoth Dynamics phase-dimmable constant current driver (DC))	Direct Wire 120VAC (Default/Blank)



FIXTURE DRAWINGS

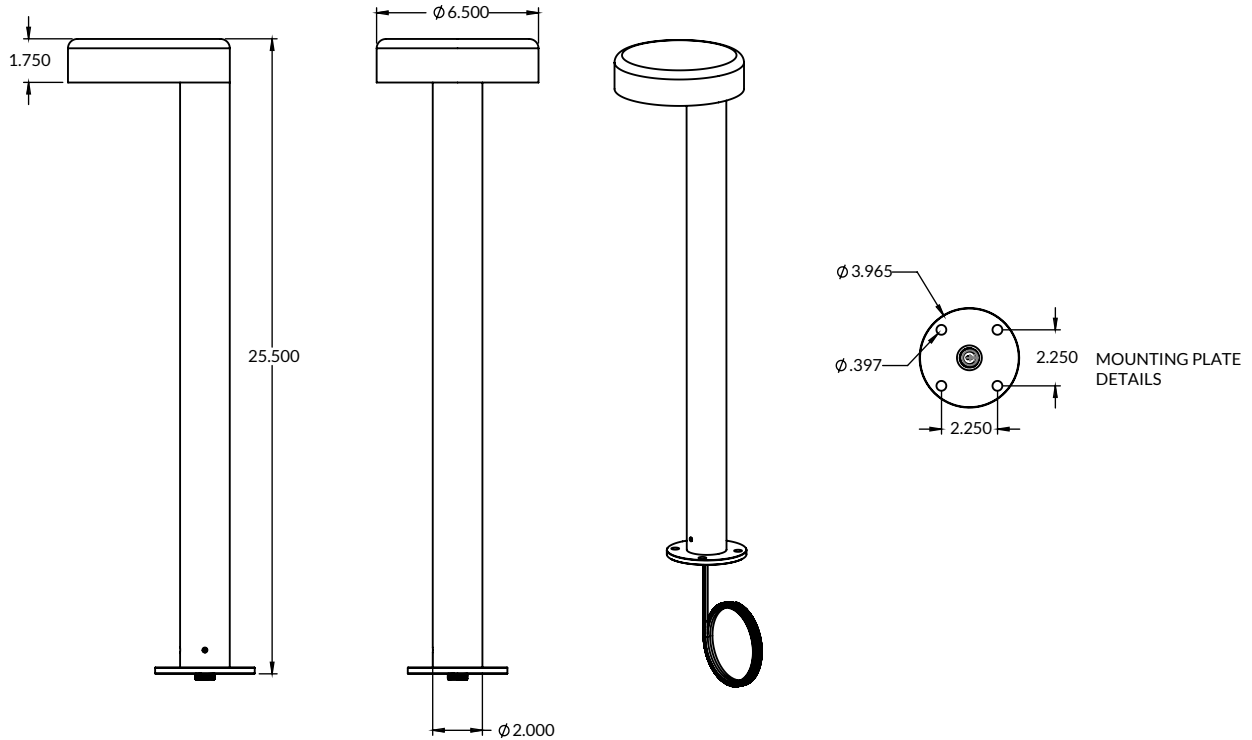

OPTIONS & ACCESSORIES

Extensions:

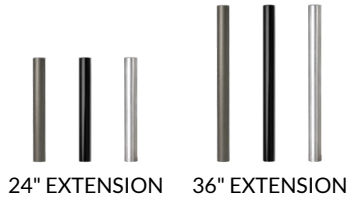

MOUNTING OPTIONS

Ground Mount:



[LV150 STAKE](#)

Building/
Structure
Mount:



[P11 MOUNTING BASE](#)



PHOTOMETRICS

P11 PATH LIGHT SSA 120° FLOOD

Input Power	15 W
Color Temperature (CCT)	3000 K
Color Rendering Index (CRI)	85
Beam Spread	120°
Max Candela Power	592cd
Delivered Lumens	1710
Efficacy	114 lm/W

Polar Graph - Intensity

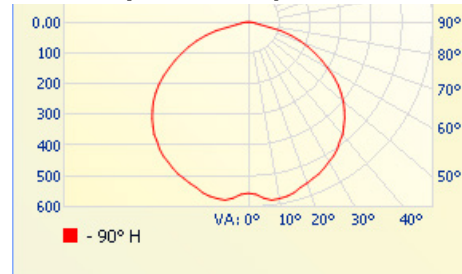

Cone of Light - Illuminance

	Illuminance at a Distance		
	Center Beam fc	Beam Width	
8.3ft	8.07 fc	10.4 ft	28.9 ft
16.7ft	1.99 fc	20.9 ft	58.1 ft
25.0ft	0.89 fc	31.3 ft	87.0 ft
33.3ft	0.5 fc	41.7 ft	115.9 ft
41.7ft	0.32 fc	52.2 ft	145.2 ft
50.0ft	0.22 fc	62.6 ft	174.1 ft

■ Vert. Spread: 64.1°
■ Horiz. Spread: 120.2°

Wattage Multiplier

Wattage	Multiplier
3 Watt	.19
9 Watt	.45
12 Watt	.82
15 Watt	1.00

CCT Multiplier

Color Temperature	Multiplier
2700 K	.97
3000 K	1.00
4000 K	1.05

Resources

[P11 Path Light – IES Version \(ZIP\)](#)

[P11 Path Light – PDF Version \(ZIP\)](#)

[Submit IES File Request](#)

Standard IES files typically represent the highest wattage, 3000K CCT, and available optics. For other configurations, submit one fixture variation per request.

[P11 Path Light – Install Guide](#)

Product Page / IES Files / Online Ordering:

gardenlightled.com/product/p11-path-light-series/

Warranty Information:

gardenlightled.com/warranty/