



Stamp OS - One Side | Specialty Light

PRODUCT DESCRIPTION

The 2"x2" Stamp Series Area Lights utilize an advanced optic to bend the light output of a Micro Max at a 90° angle to create amazing ground effects. The Stamp OS or One Side casts light via one single side.

Surface mount is ideal for horizontal and vertical applications.

PRODUCT DIMENSIONS AND BEAM SPREAD

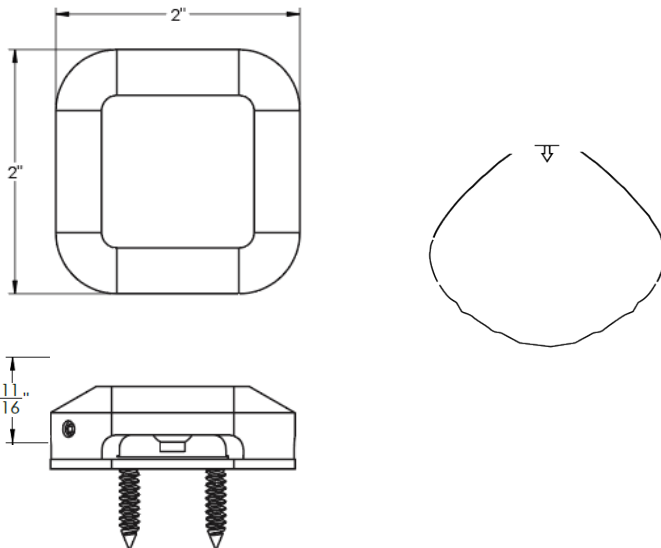

SSA

FEATURES & BENEFITS

- Built in the U.S.A.
- CNC-machined from 6061 aircraft-grade aluminum.
- U.S.A. made light engine and driver.
- Built in surge protector.
- IP67 rated.
- CREE 2 step binned LEDs with L70 over 80,000 hours.

SPECIFICATIONS

- 2" x 2" x 0.6875"
- **Construction:** 6061 aircraft-grade aluminum
- **Finishes:** Stainless Aluminum (SSA)
- **Lead Wire:** 90" 22 AWG tinned copper
- **Mounting:** Surface mount
- **Driver System:** Internal
- **Operating Voltage:** 10.5-18 VAC
- **CRI:** 80+
- **Beam Spread:** 70°

POWER CONSUMPTION

COLOR TEMPERATURE	WATTAGE	VA	LUMENS
● 3000K*	1W	2VA	115LM

ADDITIONAL COLOR TEMPERATURE OPTIONS

- 2700K ● 5000K** ● Amber** ● Blue** ● Royal Blue**
- Green** ● Red**

WARRANTY

20 Year Limited Warranty

CERTIFICATIONS



Tested to UL standards.

*3000K is stocked item. 2700K is non-stocked item that requires 5-7 business days additional lead time, special order deposit and are non-refundable.

**Special order only. Requires 5-7 business days additional lead time,