



WW | Wall Washer

PRODUCT DESCRIPTION

Ideal for uplighting, shadowing, wall washing, silhouetting, and architectural accents.

This full size Wall Washer is as functional as it is long lasting and reliable. With an even light output great for signage, property entrances and textured walls, this fixture adds beauty and security to any design.

PRODUCT DIMENSIONS & BEAM SPREAD

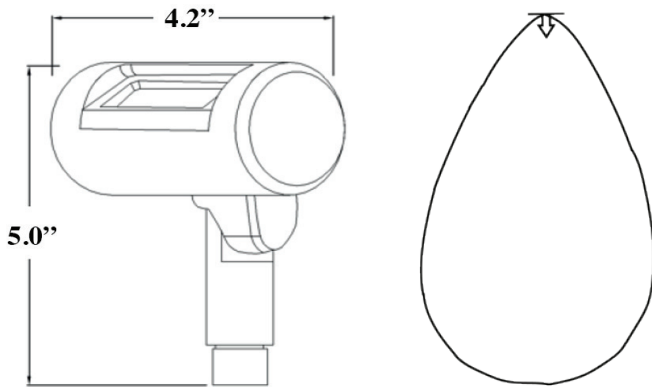

FEATURES & BENEFITS

- Built in the U.S.A.
- CNC-machined from 6061 aircraft-grade aluminum or raw brass.
- U.S.A. made light engine and driver.
- Built in surge protector.
- Adjustable knuckle for ease of light positioning.
- Field serviceable.
- IP66 rated.
- CREE 2 step binned LEDs with L70 over 80,000 hours.

SPECIFICATIONS

- **Construction:** 6061 aircraft-grade aluminum or raw brass
- **Finishes:** Architectural Bronze (AB), Black (BLK), Stainless Aluminum (SSA), Brass (BR)
- **Lead Wire:** 36" 18 AWG tinned copper
- **Mounting:** 8" LV180 ground stake
- **Lens:** Frosted flat
- **Driver System:** External
- **Operating Voltage:** 10.5-18 VAC
- **CRI:** 80+
- **Beam Spreads:** Flood



POWER CONSUMPTION

COLOR TEMPERATURE	WATTAGE	VA	LUMENS
● 3000K*	2W	4VA	130LM
	4W	7VA	210LM
	6W	11VA	280LM
	9W	15VA	380LM

ADDITIONAL COLOR TEMPERATURE OPTIONS

- 2700K ● 5000K ● Amber** ● Blue ● Royal Blue
- Green ● Red**

WARRANTY

20 Year Limited Warranty

CERTIFICATIONS



Tested to UL standards.

*Indicates stocked items. Non-stocked items require 5-7 business days additional lead time, special order deposit and are non-refundable.
**Amber not available in 6W or 9W and red not available in 9W.

IES files can be found at www.gardenlightled.com