



P1 | Path Light

PRODUCT DESCRIPTION

Ideal for pathways, walkways, patios, and small areas.

The P1 pathway light is one of the sleekest fixtures available. Slender and powerful, this light casts a beam spread that illuminates any pathway perfectly.

PRODUCT DIMENSIONS & BEAM SPREAD

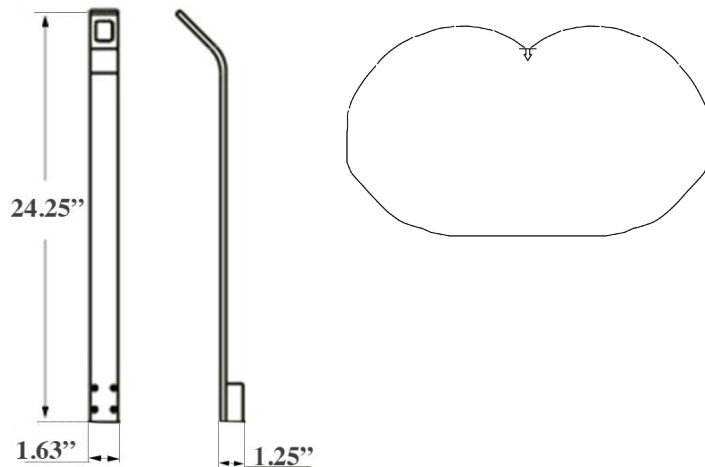

FEATURES & BENEFITS

- Built in the U.S.A.
- CNC-machined from 6061 aircraft-grade aluminum.
- U.S.A. made light engine and driver.
- Built in surge protector.
- Tempered frosted glass.
- IP66 rated.
- CREE 2 step binned LEDs with L70 over 80,000 hours.

SPECIFICATIONS

- **Construction:** 6061 aircraft-grade aluminum
- **Finishes:** Architectural Bronze (AB), Black (BLK), Stainless Aluminum (SSA)
- **Lead Wire:** 36" 18 AWG tinned copper
- **Mounting:** 8" LV180 ground stake
- **Lens:** Frosted flat
- **Driver System:** Internal
- **Operating Voltage:** 10.5-18 VAC
- **CRI:** 80+
- **Beam Spread:** Flood
- **Accessories:** Surface mount (not included)



POWER CONSUMPTION

COLOR TEMPERATURE	WATTAGE	VA	LUMENS
● 3000K*	2W	5VA	230LM

ADDITIONAL COLOR TEMPERATURE OPTIONS

- 2700K ● 5000K ● Amber ● Blue ● Royal Blue
- Green ● Red

WARRANTY

20 Year Limited Warranty

CERTIFICATIONS



Tested to UL standards.

*Indicates stocked items. Non-stocked items require 5-7 business days additional lead time, special order deposit and are non-refundable.

IES files can be found at www.gardenlightled.com